

SPECTRAL DECOMPOSITION OF THE AUTOMORPHIC SPECTRUM OF $GSp(4)$

Takuya KONNO *

Abstract

We explicitly describe the spectral decomposition of the right regular representation of $GSp(4, \mathbb{A})$ on the automorphic spectrum $L^2(GSp(4, F)\mathbb{R}_+^\times \backslash GSp(4, \mathbb{A}))$.

1 The problem

Let F be a number field, and write $\mathbb{A} = \mathbb{A}_F$ for its ring of adèles. F_∞ denotes the direct product of the completions of F at the archimedean places of F , while \mathbb{A}_f stands for the ring of finite adèles. $|\cdot|_{\mathbb{A}}$ denotes the idele norm on the idele group $\mathbb{A}_F^\times = \mathbb{A}^\times$ of F . For each place v of F , we write F_v for the completion of F at v and $|\cdot|_v$ for the module of F_v .

We fix, once for all, an algebraic closure \bar{F} of F and take any algebraic extension of F inside this. The Weil group of \bar{F}/F is denoted by W_F [Tat79]. At each place v of F , we also fix an algebraic closure \bar{F}_v of F_v and a commutative diagram

$$\begin{array}{ccc} \bar{F} & \longrightarrow & \bar{F}_v \\ \uparrow & & \uparrow \\ F & \longrightarrow & F_v \end{array}$$

This specifies a homomorphism $W_F \rightarrow W_{F_v}$, where W_{F_v} denotes the Weil group of \bar{F}_v/F_v .

As in the other articles in this volume, we consider the group $G = GSp(4)$:

$$G(R) = \{g \in GL(4, R) \mid \nu(g) := g\text{Ad}(J)^t g \in R^\times\}, \quad J = \begin{pmatrix} \mathbf{0}_2 & \mathbf{1}_2 \\ -\mathbf{1}_2 & \mathbf{0}_2 \end{pmatrix}.$$

Here $\nu : G \rightarrow \mathbb{G}_m$ denotes the similitude norm. Note that this definition makes sense not only over F but also its ring of integers \mathcal{O}_F (or any commutative ring).

The group $G(\mathbb{A})$ of adelic points of G is a locally compact unimodular group containing the group $G(F)$ of F -points as a discrete subgroup. The center Z of G is isomorphic to \mathbb{G}_m . We write \mathfrak{A}_G for the image of \mathbb{R}_+^\times diagonally embedded into $F_\infty^\times \subset \mathbb{A}^\times \simeq Z(\mathbb{A})$. We fix invariant

*Graduate School of Mathematics, Kyushu University, 812-8581 Hakozaki, Higashi-ku, Fukuoka, Japan

E-mail: takuya@math.kyushu-u.ac.jp

URL: <http://knmac.math.kyushu-u.ac.jp/~tkonno/>

measures dg and da on $G(\mathbb{A})$ and \mathfrak{A}_G , respectively, so that we have a $G(\mathbb{A})$ -invariant measure on $G(F)\mathfrak{A}_G \backslash G(\mathbb{A})$. The total measure of this quotient space is known to be finite [God63].

We seek for an ‘‘irreducible decomposition’’ of the unitary representation $R = R^G$ of $G(\mathbb{A})$ on the space

$$\mathcal{L}(G) := \left\{ \begin{array}{l} \phi : G(\mathbb{A}) \rightarrow \mathbb{C} \\ \text{measurable} \end{array} \left| \begin{array}{l} \text{(i)} \quad \phi(\gamma ag) = \phi(g), \quad \gamma \in G(F), a \in \mathfrak{A}_G \\ \text{(ii)} \quad \int_{G(F)\mathfrak{A}_G \backslash G(\mathbb{A})} |\phi(g)|^2 dg < +\infty \end{array} \right. \right\}$$

defined by

$$(R(g)\phi)(x) := \phi(xg), \quad g \in G(\mathbb{A}), \phi \in \mathcal{L}(G).$$

Since the derived group $Sp(4)$ of the G is not anisotropic, R is not completely reducible. Yet, by aid of Langlands’ spectral theory of Eisenstein series [Lan76], [MW94], we can describe the continuous spectrum by means of the completely reducible (*i.e.*, discrete) part of the similar unitary representations R^M of proper Levi subgroups $M \subset G$. Along the way, we also obtain some part (the *residual discrete spectrum*) of the discrete part of R . Our objective in this note is to give a very explicit account of this description.

2 Cuspidal spectrum

Let $P = MU \subset G$ be a parabolic subgroup, where M is a Levi component and U the unipotent radical. The quotient $U(F) \backslash U(\mathbb{A})$ is compact, so that, for any measurable function ϕ on $U(F) \backslash G(\mathbb{A})$, we can consider its *constant term*

$$\phi_P(g) := \int_{U(F) \backslash U(\mathbb{A})} \phi(ug) du, \quad g \in G(\mathbb{A}).$$

We say $\phi \in \mathcal{L}(G)$ is *cuspidal* if ϕ_P vanishes almost everywhere on $G(\mathbb{A})$ for any proper parabolic subgroup $P \subsetneq G$. Cuspidal functions in $\mathcal{L}(G)$ form a closed $G(\mathbb{A})$ -invariant subspace which we denote by $\mathcal{L}_{\text{cusp}}(G)$.

As usual, we take a Borel subgroup $B_0 = T_0U_0$ to be

$$T_0 = \left\{ m_0(a_1, a_2; \nu) := \left(\begin{array}{cc|cc} a_1 & & & \\ & a_2 & & \\ \hline & & \nu a_1^{-1} & \\ & & & \nu a_2^{-1} \end{array} \right) \left| a_i, \nu \in \mathbb{G}_m \right. \right\},$$

$$U_0 := \left\{ \left(\begin{array}{cc|cc} 1 & a & d & ab+c \\ 0 & 1 & c & b \\ \hline & & 1 & 0 \\ & & -a & 1 \end{array} \right) \left| a, b, c, d \in \mathbb{G}_a \right. \right\}.$$

Let $\mathbf{K} = \prod_v \mathbf{K}_v \subset G(\mathbb{A})$ be a T_0 -good maximal compact subgroup. That is,

- At archimedean v , the Lie algebra \mathfrak{k}_v of \mathbf{K}_v is orthogonal to the Lie algebra $\mathfrak{a}_{v,0}$ of the \mathbb{R} -split component of $T_0(F_v)$ under the Killing form.
- At non-archimedean v , \mathbf{K}_v is the stabilizer of a special point in the apartment associated to T_0 in the Bruhat-Tits building of $G(F_v)$.

- At all but a finite number of non-archimedean v , $\mathbf{K}_v = G(\mathcal{O}_v)$, where \mathcal{O}_v is the maximal compact subring (integer ring) of F_v .

We write $\mathbf{K}_\infty := \prod_{v|\infty} \mathbf{K}_v$ for the infinite (archimedean) component of \mathbf{K} . The pay-off of this choice is that we have an *Iwasawa decomposition* $G(\mathbb{A}) = P(\mathbb{A})\mathbf{K}$ for any parabolic subgroup $P \subset G$ containing T_0 . We use this later.

Using \mathbf{K} , we also introduce the *Hecke algebra* $\mathcal{H}(G(\mathbb{A}))$ of $G(\mathbb{A})$, i.e., the convolution algebra of compactly supported both sides \mathbf{K} -finite functions on $G(\mathbb{A})$.

Proposition 2.1 ([Lan76] Cor. to Lem.3.1). *The convolution operators*

$$(R(f)\phi)(x) := \int_{G(\mathbb{A})} f(g)\phi(xg) dg, \quad f \in \mathcal{H}(G(\mathbb{A}))$$

on $\mathcal{L}_{\text{cusp}}(G)$ are compact.

Since $\mathcal{H}(G(\mathbb{A}))$ contains a sequence which approximates the Dirac distribution at the identity, we can deduce the following from this.

Theorem 2.2 (Piatetsky-Shapiro). *The restriction R_{cusp} of R to $\mathcal{L}_{\text{cusp}}(G)$ decomposes into a Hilbert direct sum of irreducible unitary representations of $G(\mathbb{A})$, in which each isomorphism class of irreducible unitary representations of $G(\mathbb{A})$ occurs with finite multiplicity.*

$$\mathcal{L}_{\text{cusp}}(G) \simeq \bigoplus_{\pi \in \Pi(G(\mathbb{A}))} \pi^{\oplus m_{\text{cusp}}(\pi)}, \quad m_{\text{cusp}}(\pi) \in \mathbb{N}.$$

Here, $\Pi(G(\mathbb{A}))$ denotes the set of isomorphism classes of irreducible unitary representations of $G(\mathbb{A})$.

Remark 2.3 (On cusp forms). (i) *Recall that a function ϕ on $G(\mathbb{A})$ is called a cusp form if*

- $\phi(\gamma a g) = \phi(g)$, $\gamma \in G(F)$, $a \in \mathfrak{A}_G$, $g \in G(\mathbb{A})$;
- ϕ is right \mathbf{K} -finite: $\dim \text{span}\{(g \mapsto \phi(gk)) \mid k \in \mathbf{K}\} < \infty$;
- ϕ is $\mathfrak{Z}(G(F_\infty))$ -finite: $\dim \text{span}\{R(X)\phi \mid X \in \mathfrak{Z}(G(F_\infty))\} < \infty$;
- ϕ is slowly increasing on $G(\mathbb{A})$;
- $\phi_P = 0$ for any proper parabolic subgroup $P \subsetneq G$.

Here $\mathfrak{Z}(G(F_\infty))$ denotes the $\text{Ad}(G(F_\infty))$ -invariant part of the universal enveloping algebra of the complexified Lie algebra \mathfrak{g}_∞ of $G(F_\infty)$. We write $\mathcal{A}_{\text{cusp}}(G)$ for the space of cusp forms on $G(\mathbb{A})$. Then $\mathcal{A}_{\text{cusp}}(G)$ is a dense subspace of $\mathcal{L}_{\text{cusp}}(G)$ in the L^2 -topology.

(ii) $\mathcal{A}_{\text{cusp}}(G)$ is not a unitary representation of $G(\mathbb{A})$ but a $(\mathfrak{g}_\infty, \mathbf{K}_\infty) \times G(\mathbb{A}_f)$ -module. Moreover, for each \mathbf{K} -type κ (i.e., an isomorphism class of irreducible unitary representations of \mathbf{K}) and a \mathbb{C} -algebra homomorphism $\chi : \mathfrak{Z}(G(F_\infty)) \rightarrow \mathbb{C}$, the space $\mathcal{A}_{\text{cusp}}(G)^{\kappa, \chi}$ of $\phi \in \mathcal{A}_{\text{cusp}}(G)$ which transform under \mathbf{K} by κ and under $\mathfrak{Z}(G(F_\infty))$ by χ is finite dimensional.

Thanks to a fundamental result of Harish-Chandra, we often identify each $\pi \in \Pi(G(\mathbb{A}))$ with its associated (unitarizable) $(\mathfrak{g}_\infty, \mathbf{K}_\infty) \times G(\mathbb{A}_f)$ -module.

The determination of the multiplicity $m_{\text{cusp}}(\pi)$ in Th.2.2 seems to be a difficult problem. As for some efforts made in this direction, we refer the reader to David Whitehouse's article in this volume. In what follows, we concentrate on the spectral decomposition of the orthogonal complement of $\mathcal{L}_{\text{cusp}}(G)$.

3 Decomposition via the cuspidal data

3.1 Cuspidal spectrum for Levi subgroups

Among the parabolic subgroups, we need only the *standard parabolic subgroups* (with respect to B_0), *i.e.*, the parabolic subgroups containing B_0 . There are the following two such subgroups $P_i = M_i U_i$, ($i = 1, 2$) other than B_0 and G itself:

$$M_1 = \left\{ m_1(t, g) := \left(\begin{array}{c|cc} t & & \\ \hline & a & b \\ & \nu/t & d \\ \hline & c & \end{array} \right) \middle| \begin{array}{l} t \in \mathbb{G}_m, \nu = \det g \\ g = \begin{pmatrix} a & b \\ c & d \end{pmatrix} \in GL(2) \end{array} \right\},$$

$$U_1 = \left\{ \left(\begin{array}{cc|cc} 1 & y' & s & y \\ \hline 0 & 1 & y & 0 \\ \hline & & 1 & 0 \\ & & -y' & 1 \end{array} \right) \middle| y, y', s \in \mathbb{G}_a \right\},$$

$$M_2 = \left\{ m_2(g, \nu) := \left(\begin{array}{c|c} g & \mathbf{0}_2 \\ \hline \mathbf{0}_2 & \nu^t g^{-1} \end{array} \right) \middle| \begin{array}{l} g \in GL(2) \\ \nu \in \mathbb{G}_m \end{array} \right\},$$

$$U_2 = \left\{ \left(\begin{array}{c|c} \mathbf{1}_2 & S \\ \hline \mathbf{0}_2 & \mathbf{1}_2 \end{array} \right) \middle| S = {}^t S \in \mathbb{M}_2 \right\}.$$

We can also consider the spaces $\mathcal{L}(M) \supset \mathcal{L}_{\text{cusp}}(M)$ for any proper (standard) Levi subgroup M . The cuspidal multiplicities $m_{\text{cusp}}(\pi)$, ($\pi \in \Pi(M(\mathbb{A}))$) are well-known. In fact, we can write $\pi \in \Pi(M(\mathbb{A}))$ as

$$\begin{aligned} \omega_1 \otimes \omega_2 \otimes \omega(m_0(t_1, t_2; \nu)) &= \omega_1(t_1) \omega_2(t_2) \omega(\nu), & \text{if } M = T_0; \\ \omega \otimes \tau(m_1(t, g)) &= \omega(t) \tau(g), & \text{if } M = M_1; \\ \tau \otimes \omega(m_2(g; \nu)) &= \omega(\nu) \tau(g), & \text{if } M = M_2, \end{aligned} \tag{3.1}$$

where $\omega_1, \omega_2, \omega \in \Pi(\mathbb{A}^\times)$ (unitary characters of \mathbb{A}^\times) and $\tau \in \Pi(GL(2, \mathbb{A}))$. Since we have, for example $m_{\text{cusp}}(\omega \otimes \tau) = m_{\text{cusp}}(\omega) m_{\text{cusp}}(\tau)$ in the case $M = M_1$, it suffices to know $m_{\text{cusp}}(\pi)$ for $\pi \in \Pi(\mathbb{A}^\times)$ or $\Pi(GL(2, \mathbb{A}))$.

Theorem 3.1. (i) For both \mathbb{A}^\times and $GL(2, \mathbb{A})$, $m_{\text{cusp}}(\pi) \leq 1$.

(ii) (Classfield theory in the sense of Langlands [Mil06]) *There exists a functorial bijection between*

$$\Pi(\mathbb{A}^\times / F^\times) = \{ \omega \in \Pi(\mathbb{A}^\times) \mid m_{\text{cusp}}(\omega|_{\mathbb{A}^\times}) \neq 0, \exists \lambda \in \mathbb{C} \}$$

and the set $\text{Hom}_{\text{cont}}(W_F, \mathbb{C}^\times)$ of continuous homomorphisms from W_F to \mathbb{C}^\times .

(iii) (Converse theorem for $GL(2)$ [JL70]) *Suppose that the central character of $\pi \in \Pi(GL(2, \mathbb{A}))$ restricted to $\mathbb{R}_+^\times \subset \mathbb{A}^\times = Z(GL(2))(\mathbb{A})$ is trivial. Then $m_{\text{cusp}}(\pi) = 1$ if and only if the following conditions are satisfied for any $\omega \in \Pi(\mathbb{A}^\times / F^\times)$.*

- *The standard L and ε -functions $L(s, \pi \times \omega)$, $\varepsilon(s, \pi \times \omega)$ are entire;*
- *The functional equation $L(s, \pi \times \omega) = \varepsilon(s, \pi \times \omega) L(1 - s, \pi^\vee \times \omega^{-1})$ holds;*
- *$L(s, \pi \times \omega)$ is bounded on any region of the form $|\Re s| \leq C$.*

3.2 Poincaré series

Take a standard parabolic subgroup $P = MU \subset G$. Writing $X^*(M)_F$ for the group of F -rational characters of M , we set

$$M(\mathbb{A})^1 := \{m \in M(\mathbb{A}) \mid |\chi(m)|_{\mathbb{A}} = 1, \forall \chi \in X^*(M)_F\}.$$

Then we have the direct product decomposition $M(\mathbb{A}) = \mathfrak{A}_M \times M(\mathbb{A})^1$. For a unitary representation π of $M(\mathbb{A})$, we may twist its “ \mathfrak{A}_M -component” as follows.

(B_0) For $\lambda = (\lambda_1, \lambda_2) \in \mathfrak{a}_{0, \mathbb{C}}^{G, *} := \mathbb{C}^2$, set $\pi_\lambda := e^\lambda \otimes \pi$ where

$$e^\lambda(m_0(t_1, t_2; \nu)) := |t_1|_{\mathbb{A}}^{\lambda_1} |t_2|_{\mathbb{A}}^{\lambda_2} |\nu|_{\mathbb{A}}^{-(\lambda_1 + \lambda_2)/2}.$$

(P_1) For $\lambda \in \mathfrak{a}_{M_1, \mathbb{C}}^{G, *} := \mathbb{C}$ define π_λ as above, where $e^\lambda(m_1(t, g)) := |t|_{\mathbb{A}}^\lambda |\det g|_{\mathbb{A}}^{-\lambda/2}$.

(P_2) For $\lambda \in \mathfrak{a}_{M_2, \mathbb{C}}^{G, *} := \mathbb{C}$, define π_λ as above with $e^\lambda(m_2(g; \nu)) := |\det g|_{\mathbb{A}}^\lambda |\nu|_{\mathbb{A}}^{-\lambda}$.

For $\pi \in \Pi(M(\mathbb{A}))$, we write $\mathcal{A}_{\text{cusp}}(M)_\pi$ for the π -isotypic subspace in the $(\mathfrak{m}_\infty, \mathbf{K}_\infty \cap M(F_\infty)) \times M(\mathbb{A}_f)$ -module $\mathcal{A}_{\text{cusp}}(M)$ ¹. Of course, this is not zero if and only if $m_{\text{cusp}}(\pi) > 0$. For $\lambda \in \mathfrak{a}_{M, \mathbb{C}}^{G, *}$ as above, we set $\mathcal{A}_{\text{cusp}}(M)_{\pi_\lambda} := e^\lambda \mathcal{A}_{\text{cusp}}(M)_\pi$. Then we consider the \mathbf{K} -finite induction

$$\mathcal{A}_{\text{cusp}}(P \backslash G)_{\pi_\lambda} := \text{ind}_{\mathbf{K} \cap P(\mathbb{A})}^{\mathbf{K}} \mathcal{A}_{\text{cusp}}(M)_{\pi_{\lambda + \rho_P}},$$

where

$$\rho_P := \begin{cases} (2, 1) & \text{if } P = B_0, \\ 2 & \text{if } P = P_1, \\ 3/2 & \text{if } P = P_2 \end{cases}$$

is the square root of the modular character of $P(\mathbb{A})$. This is the space of functions $\phi : G(\mathbb{A}) \rightarrow \mathbb{C}$ satisfying the conditions:

- (i) $\phi(u\gamma a g) = e^{\lambda + \rho_P}(a) \phi(g)$, ($u \in U(\mathbb{A})$, $\gamma \in M(F)$, $a \in \mathfrak{A}_M$, $g \in G(\mathbb{A})$);
- (ii) ϕ is right \mathbf{K} -finite (see Rem.2.3);
- (iii) $M(\mathbb{A}) \ni m \mapsto \phi(mk) \in \mathbb{C}$ belongs to $\mathcal{A}_{\text{cusp}}(M)_{\pi_{\lambda + \rho_P}}$ for any $k \in \mathbf{K}$.

We regard this as a $(\mathfrak{g}_\infty, \mathbf{K}_\infty) \times G(\mathbb{A}_f)$ -module $(\mathcal{I}_P^G(\pi_\lambda), \mathcal{A}_{\text{cusp}}(P \backslash G)_{\pi_\lambda})$ under the right translation action $\mathcal{I}_P^G(\pi_\lambda)$. For any finite set \mathfrak{F} of \mathbf{K} -types, the union $\mathcal{A}_{\text{cusp}}(P \backslash G)_{\pi_\lambda}^{\mathfrak{F}}$ of the κ -isotypic subspaces in $\mathcal{A}_{\text{cusp}}(P \backslash G)_{\pi_\lambda}$, ($\kappa \in \mathfrak{F}$) form a vector bundle (of finite rank) $\mathcal{A}_{\text{cusp}}(P \backslash G)_{\pi_\lambda}^{\mathfrak{F}} \rightarrow \lambda \in \mathfrak{a}_{M, \mathbb{C}}^{G, *}$ by Rem.2.3 (ii). We view $\mathcal{A}_{\text{cusp}}(P \backslash G)_{\pi_\lambda}$ as a union of these vector bundles, and consider a special type of sections for this.

The Paley-Wiener theorem asserts that the image of $C^\infty((-r, r))$ under the Fourier transform

$$\widehat{f}(x) := \int_{\mathbb{R}} f(y) e^{xy} dy$$

consists of the entire functions $\widehat{f} \in C^\omega(\mathbb{C})$ satisfying

¹The notation $\mathcal{A}_{\text{cusp}}(M)_\pi$ cannot be replaced with $\mathcal{A}(M)_\pi$ in general, because the representation π can contribute also to the non-cuspidal spectrum. Such an example does exist. See [GGJ02].

- $\widehat{f} \in L^2(\mathbb{R})$;
- There exists $C > 0$ such that $|\widehat{f}(z)| \leq Ce^{r|z|}$, $z \in \mathbb{C}$.

We apply this to the Fourier transform for the duality between the Lie algebra \mathfrak{a}_M^G of $\mathfrak{A}_M/\mathfrak{A}_G$ and $\mathfrak{a}_{M,\mathbb{C}}^{G,*}$. and By extending the resulting Paley-Wiener functions to $G(\mathbb{A})$ by the Langlands decomposition

$$G(\mathbb{A}) = U(\mathbb{A})\mathfrak{A}_M M(\mathbb{A})^1 \mathbf{K},$$

we can define the space $P_{(M,\pi)}$ of *Paley-Wiener sections* for $\mathcal{A}_{\text{cusp}}(P \backslash G)_{\pi_\lambda} \rightarrow \lambda \in \mathfrak{a}_{M,\mathbb{C}}^{G,*}$. More precisely, $P_{(M,\pi)}$ consists of the sections $\mathfrak{a}_{M,\mathbb{C}}^{G,*} \ni \lambda \mapsto \phi_\lambda \in \mathcal{A}_{\text{cusp}}(P \backslash G)_{\pi_\lambda}^{\mathfrak{F}}$ for some finite set of \mathbf{K} -types \mathfrak{F} , whose *Fourier transform*

$$\widehat{\phi}(g) := \int_{\lambda \in \lambda_0 + i\mathfrak{a}_M^{G,*}} \phi_\lambda(g) d\lambda = \int_{\lambda \in \lambda_0 + i\mathfrak{a}_M^{G,*}} \phi_\lambda(mk) e^\lambda(a) d\lambda$$

($g = uamk$, $u \in U(\mathbb{A})$, $a \in \mathfrak{A}_M$, $m \in M(\mathbb{A})^1$, $k \in \mathbf{K}$) is smooth and compactly supported modulo \mathfrak{A}_G in $a \in \mathfrak{A}_M$. One can easily verify that the series

$$\theta_\phi(g) := \sum_{\gamma \in P(F) \backslash G(F)} \widehat{\phi}(\gamma g)$$

converges absolutely for $\phi \in P_{(M,\pi)}$. We write $W_0 = W_0^G := \text{Norm}(T_0, G)/T_0$ for the Weyl group of T_0 in G .

Theorem 3.2. (i) Take a standard parabolic subgroup $P = MU \subset G$ and $\pi \in \Pi(M(\mathbb{A}))$ whose central character ω_π restricted to \mathfrak{A}_M is trivial. Then $\theta_\phi \in \mathcal{L}(G)$ for any $\phi \in P_{(M,\pi)}$. (ii) We write $[M, \pi]$ for the W_0 -conjugacy class of pairs (M, π) as in (i). Let $\mathcal{L}(G)_{[M,\pi]}$ be the closed span of θ_ϕ , $\phi \in P_{(M',\pi')}$ where (M', π') runs over $[M, \pi]$. Then we have a Hilbert direct sum decomposition

$$\mathcal{L}(G) = \bigoplus_{[M,\pi]} \mathcal{L}(G)_{[M,\pi]}.$$

Outline of the proof. For the density of $\sum_{[M,\pi]} \{\theta_\phi \mid \phi \in P_{(M',\pi')}, (M', \pi') \in [M, \pi]\}$ in $\mathcal{L}(G)$, see [MW94, Th.II.1.12]. This follows from Th.2.2 and the so-called *Langlands lemma*. That is, if the ‘‘cuspidal components’’ of the constant terms ϕ_P of $\phi \in \mathcal{L}(G)$ are zero for any $B_0 \subseteq P \subseteq G$, then $\phi = 0$. The orthogonality of the summands follows from the inner product formula for θ_ϕ 's (Th.4.3). \square

4 L^2 -inner product of Poincaré series

4.1 Eisenstein series

We write Σ_0 for the set of roots of T_0 in G . The positive system associated to B_0 is denoted by $\Sigma_{B_0} \subset \Sigma_0$. Then the set Δ_{B_0} of simple roots in Σ_{B_0} consists of

$$\alpha_1(m_0(t_1, t_2; \nu)) := t_1/t_2, \quad \alpha_2(m_0(t_1, t_2; \nu)) := t_2^2/\nu.$$

For $P_i = M_i U_i$, ($i = 1, 2$), the set $\Delta_{P_i} = \{\alpha_{M_i} := \alpha_i|_{A_{M_i}}\}$ of non-trivial restrictions of $\alpha \in \Delta_{B_0}$ to the center A_{M_i} of M_i is called the set of *simple roots* of (P_i, A_{M_i}) . The corresponding coroots $\alpha^\vee \in \mathfrak{a}_M^G$, ($\alpha \in \Delta_M$) are given by

$$\begin{aligned}\alpha_1^\vee(\lambda) &= \lambda_1 - \lambda_2, & \alpha_2^\vee(\lambda) &= \lambda_2, & \lambda &= (\lambda_1, \lambda_2) \in \mathfrak{a}_0^{G,*}, \\ \alpha_{M_i}^\vee(\lambda) &:= \lambda, & \lambda &\in \mathfrak{a}_{M_i}^{G,*}, & (i &= 1, 2).\end{aligned}$$

Proposition 4.1 ([Lan76] Lem.4.1). *Let $(P = MU, \pi)$ be as above, and take $\phi \in P_{(M, \pi)}$.*

(i) *For $\lambda \in \mathfrak{a}_{M, \mathbb{C}}^{G,*}$, the (cuspidal) Eisenstein series*

$$E_P(\phi_\lambda, g) := \sum_{\gamma \in P(F) \backslash G(F)} \phi_\lambda(\gamma g)$$

converges absolutely if $\alpha^\vee(\Re \lambda - \rho_P) > 0$ for any $\alpha \in \Delta_P$. Here $\Re \lambda$ denotes the real part of λ .

(ii) *At such sufficiently positive $\lambda \in \mathfrak{a}_{M, \mathbb{C}}^{G,*}$, $E_P(\phi_\lambda)$ is an automorphic form on $G(\mathbb{A})$ (i.e., satisfies the first four conditions in Rem.2.3), and satisfies the $\mathcal{H}(G(\mathbb{A}))$ -equivariance:*

$$E_P(\mathcal{I}_P^G(\pi_\lambda, f)\phi_\lambda) = R(f)E_P(\phi_\lambda), \quad f \in \mathcal{H}(G(\mathbb{A})).$$

(iii) *For sufficiently positive $\lambda_0 \in \mathfrak{a}_M^{G,*}$, we have*

$$\theta_\phi = \int_{\lambda \in \lambda_0 + i\mathfrak{a}_M^{G,*}} E_P(\phi_\lambda) d\lambda.$$

The assertions other than the convergence are rather formal and easy to prove.

Now we introduce the intertwining operators. For a standard Levi subgroup $M \subset G$, W_M denotes the set of cosets $wW_0^M \subset W_0$ such that $w(M)$ is again a standard Levi subgroup of G . For our present $G = GSp(4)$, this coincides with the Weyl group $W(M) := \text{Norm}(M, G)/M$ of M in G . If we write $r_i \in W_0$ for the simple reflection attached to $\alpha_i \in \Delta_{B_0}$, then we have

$$W_0 = \{1, r_1, r_2, r_1 r_2, r_2 r_1, w_{M_1} := r_1 r_2 r_1, w_{M_2} := r_2 r_1 r_2, w_0 := r_1 r_2 r_1 r_2\}$$

and $W_{M_i} = W(M_i) = \{1, w_{M_i}\}$, ($i = 1, 2$). For $w \in W_M$, we write $P_w = w(M)U_w \subset G$ for the standard parabolic subgroup having $w(M)$ as a Levi component. We also fix a representative $\tilde{w} \in \text{Norm}(T_0, G)$ for each $w \in W_0$.

Proposition 4.2 ([MW94] II.1.6–7). *Take a standard parabolic subgroup $P = MU$ and $\pi \in \Pi(M(\mathbb{A}))$ with $\omega_\pi|_{\mathfrak{a}_M} = \mathbb{1}$.*

(i) *For $w \in W_M$ and $\lambda \in \mathfrak{a}_{M, \mathbb{C}}^{G,*}$, the integral*

$$M(w, \pi_\lambda)\phi(g) := \int_{(w(U) \cap U_w) \backslash U_w(\mathbb{A})} \phi(\tilde{w}^{-1}ug) du$$

converges absolutely if $\alpha^\vee(\Re \lambda - \rho_P) > 0$, for any $\alpha \in \Delta_P$.

(ii) *At such $\lambda \in \mathfrak{a}_{M, \mathbb{C}}^{G,*}$, this defines an intertwining operator (i.e., a $(\mathfrak{g}_\infty, \mathbf{K}_\infty) \times G(\mathbb{A}_f)$ -homomorphism)*

$$M(w, \pi_\lambda) : \mathcal{A}_{\text{cusp}}(P \backslash G)_{\pi_\lambda} \longrightarrow \mathcal{A}_{\text{cusp}}(P_w \backslash G)_{w(\pi_\lambda)},$$

where $w(\pi_\lambda) := \pi_\lambda \circ \text{Ad}(\tilde{w})^{-1}$.

(iii) For $\phi \in P_{(M,\pi)}$, the constant term of $E_P(\phi_\lambda)$ along a standard parabolic subgroup $P' = M'U'$ is given by

$$E_P(\phi_\lambda)_{P'} = \sum_{\substack{w \in W_M \\ w(M) \subset M'}} E_{P'_w}^{P'}(M(w, \pi_\lambda)\phi_\lambda),$$

where $E_{P'}^{P'}(\phi_\lambda, g) := \sum_{\gamma \in P(F) \backslash P'(F)} \phi_\lambda(\gamma g)$.

(iv) We have the adjonction formula

$$\langle M(w, \pi_\lambda)\phi, \phi' \rangle = \langle \phi, M(w^{-1}, w(\pi)_{-w(\bar{\lambda})})\phi' \rangle$$

for $\phi \in \mathcal{A}_{\text{cusp}}(P \backslash G)_{\pi_\lambda}$, $\phi' \in \mathcal{A}_{\text{cusp}}(P_w \backslash G)_{w(\pi)_{-w(\bar{\lambda})}}$. Here, the pairing is defined by

$$\langle \phi_\lambda, \phi'_{-\bar{\lambda}} \rangle := \int_{\mathbf{K}} \int_{M(F) \backslash M(\mathbb{A})^1} \phi_\lambda(mk) \overline{\phi'_{-\bar{\lambda}}(mk)} dm dk$$

for $\phi_\lambda \in \mathcal{A}(P \backslash G)_{\pi_\lambda}$, $\phi'_{-\bar{\lambda}} \in \mathcal{A}(P \backslash G)_{\pi_{-\bar{\lambda}}}$.

Note that both $M(w, \pi_\lambda)\phi$ and $w(\pi_\lambda)$ are independent of the choice of \tilde{w} , since $\phi \in \mathcal{A}_{\text{cusp}}(P \backslash G)_{\pi_\lambda}$ is left $M(F)$ -invariant.

4.2 L^2 -inner product of Poincaré series

Theorem 4.3 ([MW94] II.2.1). *Take pairs $(P = MU, \pi)$, $(P' = M'U', \pi')$ as above. The inner product of $\theta_\phi, \theta_{\phi'}$, ($\phi \in P_{(M,\pi)}$, $\phi' \in P_{(M',\pi')}$) in $\mathcal{L}(G)$ is given by*

$$\begin{aligned} \langle \theta_\phi, \theta_{\phi'} \rangle &= \int_{\lambda_0 + i\mathfrak{a}_M^{G,*}} A(\phi, \phi')(\pi_\lambda) d\lambda, \\ A(\phi, \phi')(\pi_\lambda) &:= \sum_{\substack{w \in W_M \\ w(M) = M'}} \langle M(w, \pi_\lambda)\phi_\lambda, \phi'_{-w(\bar{\lambda})} \rangle \end{aligned}$$

if $[M, \pi] = [M', \pi']$, and 0 otherwise. Here, $\lambda_0 \in \mathfrak{a}_M^{G,*}$ is any point satisfying $\alpha^\vee(\lambda_0 - \rho_P) > 0$ for any $\alpha \in \Delta_P$. The pairing on the right hand side of the second row is the one defined in Prop.4.2.

Proof. We note $G(F)\mathfrak{A}_G \backslash G(\mathbb{A}) \simeq G(F) \backslash G(\mathbb{A})^1$. Using the integration formula for the decomposition $G(\mathbb{A})^1 = U'(F)\mathfrak{A}_{M'} \backslash M'(F)\mathfrak{A}_{M'} \backslash M'(\mathbb{A})^1 \mathbf{K}$, we have

$$\begin{aligned} \langle \theta_\phi, \theta_{\phi'} \rangle &= \int_{G(F) \backslash G(\mathbb{A})^1} \theta_\phi(g) \sum_{\gamma \in P'(F) \backslash G(F)} \overline{\widehat{\phi}'(\gamma g)} dg = \int_{P'(F) \backslash G(\mathbb{A})^1} \theta_\phi(g) \overline{\widehat{\phi}'(g)} dg \\ &= \int_{\mathbf{K}} \int_{M'(F) \backslash M'(\mathbb{A})^1} \int_{\mathfrak{A}_{M'}^G} \int_{U'(F) \backslash U'(\mathbb{A})} \theta_\phi(uamk) du \\ &\quad \times \overline{\widehat{\phi}'(amk)} e^{-2\rho_{P'}(a)} da dm dk \\ &= \int_{\mathbf{K}} \int_{\mathfrak{A}_{M'}^G} \int_{M'(F) \backslash M'(\mathbb{A})^1} \theta_{\phi, P'}(amk) \overline{\widehat{\phi}'(amk)} dm e^{-2\rho_{P'}(a)} da dk. \end{aligned}$$

The constant term $\theta_{\phi, P'}$ is calculated by applying the Fourier transform to Prop.4.2 (iii):

$$\theta_{\phi, P'} = \sum_{\substack{w \in W_M \\ w(M) \subset M'}} \int_{\lambda_0 + i\mathfrak{a}_M^{G, *}} E_{P_w}^{P'}(M(w, \pi_\lambda)\phi_\lambda) d\lambda.$$

Here λ_0 is a sufficiently positive element of $\mathfrak{a}_M^{G, *}$. Putting this and the definition of $\widehat{\phi}'$ into the above, we get

$$\begin{aligned} \langle \theta_\phi, \theta_{\phi'} \rangle &= \sum_{\substack{w \in W_M \\ w(M) \subset M'}} \int_{\mathbf{K}} \int_{\mathfrak{a}_{M'}^G} \int_{M'(F) \backslash M'(\mathbb{A})^1} \int_{\lambda_0 + i\mathfrak{a}_M^{G, *}} E_{P_w}^{P'}(M(w, \pi_\lambda)\phi_\lambda, amk) d\lambda \\ &\quad \times \int_{\lambda'_0 + i\mathfrak{a}_{M'}^{G, *}} \overline{\phi'_{\lambda'}(amk)} d\lambda' dm e^{-2\rho_{P'}(a)} da dk \\ &= \sum_{\substack{w \in W_M \\ w(M) \subset M'}} \int_{\mathbf{K}} \int_{\mathfrak{a}_{M'}^G} \int_{\lambda_0 + i\mathfrak{a}_M^{G, *}} \int_{\lambda'_0 + i\mathfrak{a}_{M'}^{G, *}} \\ &\quad \times \int_{M'(F) \backslash M'(\mathbb{A})^1} E_{P_w}^{P'}(M(w, \pi_\lambda)\phi_\lambda, amk) \overline{\phi'_{\lambda'}(amk)} dm \\ &\quad d\lambda' d\lambda e^{-2\rho_{P'}(a)} da dk. \end{aligned} \tag{4.1}$$

Note that the integral on λ' is independent of $\lambda'_0 \in \mathfrak{a}_{M'}^{G, *}$ by Cauchy's integration theorem. Writing $\varphi := M(w, \pi_\lambda)\phi_\lambda$ for brevity, the inner integral becomes

$$\begin{aligned} &\int_{M'(F) \backslash M'(\mathbb{A})^1} \sum_{\gamma \in P_w(F) \backslash P'(F)} \varphi(\gamma amk) \overline{\phi'_{\lambda'}(amk)} dm \\ &= \int_{(U_w \cap M')(\mathbb{A}) w(M)(F) \backslash M'(\mathbb{A})^1} \varphi(amk) \int_{(U_w \cap M')(F) \backslash (U_w \cap M')(\mathbb{A})} \phi'_{\lambda'}(aumk) du dm \\ &= \begin{cases} \int_{M'(F) \backslash M'(\mathbb{A})^1} \varphi(amk) \overline{\phi'_{\lambda'}(amk)} dm & \text{if } P_w = P', \\ 0 & \text{otherwise,} \end{cases} \end{aligned}$$

since $m \mapsto \phi'_{\lambda'}(amk)$ belongs to $e^{\lambda' + \rho_{P'}} \mathcal{A}_{\text{cusp}}(M')_{\pi'}$. Thus (4.1) simplifies to

$$\begin{aligned} \langle \theta_\phi, \theta_{\phi'} \rangle &= \sum_{\substack{w \in W_M \\ w(M) = M'}} \int_{\mathbf{K}} \int_{M'(F) \backslash M'(\mathbb{A})^1} \int_{\mathfrak{a}_{M'}^G} \int_{\lambda_0 + i\mathfrak{a}_M^{G, *}} \int_{-w(\lambda_0) + i\mathfrak{a}_{M'}^{G, *}} \\ &\quad e^{w(\lambda) + \rho_{P'}(a)} M(w, \pi_\lambda)\phi_\lambda(mk) e^{\bar{\lambda}' + \rho_{P'}(a)} \overline{\phi'_{\lambda'}(mk)} d\lambda' d\lambda e^{-2\rho_{P'}(a)} da dm dk \\ &= \sum_{\substack{w \in W_M \\ w(M) = M'}} \int_{\mathbf{K}} \int_{M'(F) \backslash M'(\mathbb{A})^1} \int_{\mathfrak{a}_{M'}^G} \\ &\quad \left(\int_{\lambda_0 + i\mathfrak{a}_M^{G, *}} \int_{-w(\lambda_0) + i\mathfrak{a}_{M'}^{G, *}} M(w, \pi_\lambda)\phi_\lambda(mk) \overline{\phi'_{\lambda'}(mk)} e^{w(\lambda) + \bar{\lambda}'}(a) d\lambda' d\lambda \right) da dm dk. \end{aligned} \tag{4.2}$$

Here we have chosen $\lambda'_0 := -w(\lambda_0)$ in the term associated to $w \in W_M$, $w(M) = M'$. If we put $\lambda_1 := (\lambda + w^{-1}(\lambda'))/2$, $\lambda_2 := \lambda' - w(\lambda)$, then the inside of the brace becomes

$$\int_{i\mathfrak{a}_M^{G,*}} \int_{-2w(\lambda_0)+i\mathfrak{a}_{M'}^{G,*}} M(w, \pi_{\lambda_1-w^{-1}(\lambda_2)/2}) \phi_{\lambda_1-w^{-1}(\lambda_2)/2}(mk) \overline{\phi'_{w(\lambda_1)+\lambda_2/2}(mk)} e^{-i\Im\lambda_2(a)} d\lambda_2 d\lambda_1$$

putting $\lambda' := i\Im\lambda_2$,

$$= \int_{i\mathfrak{a}_M^{G,*}} \int_{i\mathfrak{a}_{M'}^{G,*}} M(w, \pi_{\lambda_0+\lambda_1-w^{-1}(\lambda')/2}) \phi_{\lambda_0+\lambda_1-w^{-1}(\lambda')/2}(mk) \times \overline{\phi'_{w(\lambda_1-\lambda_0)+\lambda'/2}(mk)} e^{-\lambda'(a)} d\lambda' d\lambda_1$$

putting $\lambda := \lambda_0 + \lambda_1$ and noting $\lambda_0 \in \mathfrak{a}_M^{G,*}$, $\lambda_1 \in i\mathfrak{a}_{M'}^{G,*}$,

$$= \int_{\lambda_0+i\mathfrak{a}_M^{G,*}} \int_{i\mathfrak{a}_{M'}^{G,*}} M(w, \pi_{\lambda-w^{-1}(\lambda')/2}) \phi_{\lambda-w^{-1}(\lambda')/2}(mk) \overline{\phi'_{-w(\bar{\lambda})+\lambda'/2}(mk)} \times e^{-\lambda'(a)} d\lambda' d\lambda_1.$$

Here $\Im(\cdot)$ denotes the imaginary part of (\cdot) . Putting this into (4.2) and applying the Fourier inversion formula, we obtain

$$\begin{aligned} \langle \theta_\phi, \theta_{\phi'} \rangle &= \sum_{\substack{w \in W_M \\ w(M)=M'}} \int_{\mathbf{K}} \int_{M'(F) \backslash M'(\mathbb{A})^1} \int_{\lambda_0+i\mathfrak{a}_M^{G,*}} M(w, \pi_\lambda) \phi_\lambda(mk) \overline{\phi'_{-w(\bar{\lambda})}(mk)} d\lambda dm dk \\ &= \int_{\lambda_0+i\mathfrak{a}_M^{G,*}} \sum_{\substack{w \in W_M \\ w(M)=M'}} \langle M(w, \pi_\lambda) \phi_\lambda, \phi'_{-w(\bar{\lambda})} \rangle d\lambda, \end{aligned}$$

as stated. □

5 Analytic behavior of intertwining operators

The inner product formula in Th.4.3 does not yield the spectral decomposition immediately, because the pairings on the right hand side are not $G(\mathbb{A})$ -invariant. To obtain a $G(\mathbb{A})$ -equivariant formula, we need to move the integration axis to the unitary axis $i\mathfrak{a}_M^{G,*}$. By the general theory due to Langlands, the operators $M(w, \pi_\lambda)$ and the cuspidal Eisenstein series are all meromorphically continued to the whole $\mathfrak{a}_{M,\mathbb{C}}^{G,*}$, so that we can still use these to describe the resulting formula. But to obtain explicit description of the result, we need to know the analytic behavior of these functions in the “positive half space” of $\mathfrak{a}_{M,\mathbb{C}}^{G,*}$. Here we investigate these analytic properties for $G = GSp(4)$ using the Langlands-Shahidi theory.

5.1 Normalization of intertwining operators

Recall that the L -group of G is a direct product ${}^L G = \widehat{G} \times W_F$, where $\widehat{G} = G(\mathbb{C}) = GSp(4, \mathbb{C})$. The L -groups of standard parabolic subgroups are identified with subgroups of ${}^L G$ as follows. (See *e.g.*, [Kon] for more details.)

$$\begin{aligned} {}^L B_0 &= {}^L T_0 \times \widehat{U}_0 = B_0(\mathbb{C}) \times W_F, \\ {}^L P_1 &= {}^L M_1 \times \widehat{U}_1 = P_2(\mathbb{C}) \times W_F, \\ {}^L P_2 &= {}^L M_2 \times \widehat{U}_2 = P_1(\mathbb{C}) \times W_F. \end{aligned}$$

Recall the Langlands correspondence for tori of \mathbb{G}_m (Th.3.1). Also for a cuspidal automorphic representation τ of $GL(2, \mathbb{A})$, we write $\varphi_\tau : \mathcal{L}_F \rightarrow GL(2, \mathbb{C})$ for its conjectural Langlands parameter. Here \mathcal{L}_F is the hypothetical Langlands group of \bar{F}/F . We need these objects only to make it easy to memorize the normalization factors for intertwining operators, and do not use them in any practical computation.

Now take $P = MU \subset G$ and $\pi \in \Pi(M(\mathbb{A}))$ with $m_{\text{cusp}}(\pi) \neq 0$ or equivalently $\mathcal{A}_{\text{cusp}}(M)_\pi \neq 0$. Using the above notation, the Langlands parameter $\varphi_\pi : \mathcal{L}_F \rightarrow {}^L G$ of π is given as follows.

(B_0) Writing $\pi = \omega_1 \otimes \omega_2 \otimes \omega$ (see (3.1)),

$$\varphi_\pi = \text{diag}(\omega_1 \omega_2 \omega, \omega_1 \omega, \omega, \omega_2 \omega) \times p_{W_F}.$$

(P_1) Writing $\pi \simeq \omega \otimes \tau$ as in (3.1),

$$\varphi_\pi = \begin{pmatrix} \omega \varphi_\tau & \mathbf{0}_2 \\ \mathbf{0}_2 & \omega_\tau {}^t \varphi_\tau^{-1} \end{pmatrix} \times p_{W_F}.$$

(P_2) Writing $\pi \simeq \omega \otimes \tau$ as in (3.1),

$$\varphi_\pi = \begin{pmatrix} \omega \omega_\tau & & & \\ & \omega a_\tau & & \omega b_\tau \\ & & \omega & \\ & \omega c_\tau & & \omega d_\tau \end{pmatrix} \times p_{W_F},$$

where we have written $\varphi_\tau = \begin{pmatrix} a_\tau & b_\tau \\ c_\tau & d_\tau \end{pmatrix}$.

Take $w \in W_M$. We write $\widehat{\mathfrak{u}}, \widehat{\mathfrak{u}}_w$ for the Lie algebra of \widehat{U} and \widehat{U}_w , respectively. Associated to $\pi \in \Pi(M(\mathbb{A}))$ as above and the adjoint representation $\rho_w : {}^L M \rightarrow GL(\widehat{\mathfrak{u}}/w^{-1}(\widehat{\mathfrak{u}}) \cap \widehat{\mathfrak{u}})$ is the automorphic L and ε -functions

$$L(s, \pi, \rho_w) := L(s, \rho_w \circ \varphi_\pi), \quad \varepsilon(s, \pi, \rho_w) := \varepsilon(s, \rho_w \circ \varphi_\pi),$$

where the right hand sides are the Artin L and ε -functions associated to $\rho_w \circ \varphi_\pi$. Using these, we define the Langlands normalization factor for $M(w, \pi_\lambda)$:

$$r(w, \pi_\lambda) := \frac{L(0, \pi_\lambda, \rho_w)}{L(1, \pi_\lambda, \rho_w) \varepsilon(0, \pi_\lambda, \rho_w)}.$$

To be explicit, we have the following list. We write π_λ as in §3.2, and abbreviate $\rho_{w_{M_i}}$ as ρ_{M_i} , ($i = 1, 2$). Note that any of the automorphic L -functions involved can be obtained from some (well-known) integral representation, and we do not need the global Langlands conjecture !

(B₀) For simple reflections $s_i \in W_0$ attached to $\alpha_i \in \Delta_{B_0}$, we have

$$L(0, \pi_\lambda, \rho_{s_1}) = L(\lambda_1 - \lambda_2, \omega_1 \omega_2^{-1}), \quad L(0, \pi_\lambda, \rho_{s_2}) = L(\lambda_2, \omega_2).$$

For general $w \in W_0$, we take a reduced expression $w = s_{i_1} \cdots s_{i_\ell}$ by the simple reflections. Then

$$L(0, \pi_\lambda, \rho_w) = \prod_{j=1}^{\ell} L(0, s_{i_{j+1}} \cdots s_{i_\ell}(\pi_\lambda), \rho_{s_{i_j}}).$$

(P₁) We have

$$L(0, \pi_\lambda, \rho_{M_1}) = L(\lambda, \text{Ad}^2(\tau) \times \omega),$$

the *adjoint square L-function* of τ twisted by ω [GJ78].

(P₂) We have

$$L(0, \pi_\lambda, \rho_{M_2}) = L(\lambda, \tau) L(2\lambda, \omega_\tau).$$

5.2 Poles of intertwining operators

First we recall the general results on meromorphic continuation which are valid for general reductive groups.

Proposition 5.1 ([MW94] IV.1). *Take $(P = MU, \pi)$ as above and $\phi \in P_{(M, \pi)}$.*

(i) *The functions $E_P(\phi_\lambda)$, $M(w, \pi_\lambda)$, ($w \in W_M$) are meromorphically continued to the whole $\mathfrak{a}_{M, \mathbb{C}}^{G, *}$.*

(ii) *The properties Prop.4.1 (ii), Prop.4.2 (ii), (iii) as well as the functional equations*

$$E_{P_w}(M(w, \pi_\lambda)\phi_\lambda) = E_P(\phi_\lambda), \quad (w \in W_M),$$

$$M(w, w'(\pi)) \circ M(w', \pi) = M(ww', \pi), \quad (w' \in W_M, w \in W_{w'(M)})$$

are valid as identities of meromorphic functions.

(iii) *For $\lambda \in i\mathfrak{a}_M^{G, *}$, we have $\|M(w, \pi_\lambda)\phi\| = \|\phi\|$ for any $\phi \in \mathcal{A}_{\text{cusp}}(P \backslash G)_{\pi_\lambda}$. Here, the norm $\|\cdot\|$ is the one associated to the pairing introduced in Prop.4.2.*

The assertion (iii) is a consequence of the functional equation (ii) and the adjunction formula Prop.4.2 (iv).

Now for the present G , any $\pi \in \Pi(M(\mathbb{A}))$ which appears in the cuspidal spectrum is *generic* in the sense that it admits a *Whittaker model*. For such cuspidal representations, we have the following consequences of the Langlands-Shahidi theory [Sha90].

Suppose $m_{\text{cusp}}(\pi) \neq 0$, so that $\mathcal{A}_{\text{cusp}}(M)_\pi \simeq \pi$ (see Th.3.1). We have the restricted tensor product decomposition $\pi \simeq \otimes_v \pi_v$. Fix an associated isomorphism

$$\Phi_\pi : \mathcal{A}_{\text{cusp}}(P \backslash G)_\pi \xrightarrow{\sim} \bigotimes_v I_P^G(\pi_v),$$

where $I_P^G(\pi_v) := \text{ind}_{P(F_v)}^{G(F_v)}(\pi_v \otimes \mathbb{1}_{U(F_v)})$ denotes the representation of $G(F_v)$ parabolically induced from π_v . By multiplying $e^{\lambda + \rho_P}$ (viewed as a function of the \mathfrak{A}_M -component of $G(\mathbb{A}) = U(\mathbb{A})M(\mathbb{A})^1\mathfrak{A}_M\mathbf{K}$), this yields $\Phi_{\pi_\lambda} : \mathcal{A}_{\text{cusp}}(P \backslash G)_{\pi_\lambda} \xrightarrow{\sim} \bigotimes_v I_P^G(\pi_{v, \lambda})$ for any $\lambda \in \mathfrak{a}_{M, \mathbb{C}}^{G, *}$.

On each $I_P^G(\pi_{v,\lambda})$, we have the local intertwining operator

$$M(\tilde{w}, \pi_{v,\lambda})\phi_v(g) := \int_{(w(U) \cap U_w)(F_v) \backslash U_w(F_v)} \phi(\tilde{w}^{-1}ug) du, \quad \phi_v \in I_P^G(\pi_{v,\lambda}).$$

This converges absolutely at $\lambda \in \mathfrak{a}_{M,\mathbb{C}}^{G,*}$ satisfying $\alpha^\vee(\Re\lambda) \gg 0$ for any $\alpha \in \Sigma_P$ such that $w(\alpha) \notin \Sigma_{P_w}$. Moreover, it extends to a meromorphic function of $\lambda \in \mathfrak{a}_{M,\mathbb{C}}^{G,*}$. Outside its poles, it defines an intertwining operator

$$M(\tilde{w}, \pi_{v,\lambda}) : I_P^G(\pi_{v,\lambda}) \longrightarrow I_{P_w}^G(w(\pi_{v,\lambda})).$$

Note that the local operator depends on the representative \tilde{w} of w . By construction, the following diagram commutes, for $\lambda \in \mathfrak{a}_{M,\mathbb{C}}^{G,*}$ with $\alpha^\vee(\Re\lambda) \gg 0, \forall \alpha \in \Delta_P$:

$$\begin{array}{ccc} \mathcal{A}(P \backslash G)_{\pi_\lambda} & \xrightarrow{M(w, \pi_\lambda)} & \mathcal{A}(P_w \backslash G)_{w(\pi_\lambda)} \\ \Phi_{\pi_\lambda} \downarrow & & \downarrow \Phi_{w(\pi_\lambda)} \\ \otimes_v I_P^G(\pi_{v,\lambda}) & \xrightarrow{\otimes_v M(\tilde{w}, \pi_{v,\lambda})} & \otimes_v I_{P_w}^G(w(\pi_{v,\lambda})) \end{array}$$

Also, if we fix a non-trivial character $\psi = \otimes_v \psi_v : \mathbb{A}/F \rightarrow \mathbb{C}^\times$, we have an Euler product decomposition of the normalization factor $r(w, \pi_\lambda) = \prod_v r(w, \pi_{v,\lambda}, \psi_v)$, where

$$r(w, \pi_{v,\lambda}, \psi_v) := \frac{L(0, \pi_{v,\lambda}, \rho_w)}{L(1, \pi_{v,\lambda}, \rho_w) \varepsilon(0, \pi_{v,\lambda}, \rho_w, \psi_v)}.$$

Proposition 5.2. (i) *The normalized intertwining operator*

$$N(\tilde{w}, \pi_{v,\lambda}, \psi_v) := r(w, \pi_{v,\lambda}, \psi_v)^{-1} M(\tilde{w}, \pi_{v,\lambda})$$

is holomorphic on

$$C_P(w) := \{\lambda \in \mathfrak{a}_{M,\mathbb{C}}^{G,*} \mid \alpha^\vee(\Re\lambda) \geq 0, \alpha \in \Sigma_P \setminus w^{-1}(\Sigma_{P_w})\}$$

(ii) *At all but finite number of non-archimedean v , $I_P^G(\pi_{v,\lambda})$ contains a \mathbf{K}_v -fixed vector $\phi_{\pi_{v,\lambda}}^0$ with respect to which, the restricted tensor product is taken. For this vector, we have*

$$N(\tilde{w}, \pi_{v,\lambda}, \psi_v) \phi_{\pi_{v,\lambda}}^0 = \phi_{w(\pi_{v,\lambda})}^0,$$

provided that ψ_v is of order zero and the measure on any unipotent subgroup $V \subset G$ is chosen in such a way that $\text{meas}(V(F_v) \cap \mathbf{K}_v) = 1$.

Outline of the proof. (i) When π_v is tempered, this is [Sha90, Th.7.9] valid for any quasisplit group. A case-by-case verification proves the non-tempered case for the present G .

(ii) This is no other than the Gindikin-Karepelevich formula [Lan71, p.45]. \square

Now we take $\phi \in P_{(M,\pi)}$. We may assume $\Phi_{\pi_\lambda}(\phi_\lambda)$ is of the form $\otimes_v \phi_{v,\lambda}$, $\phi_{v,\lambda} \in I_P^G(\pi_{v,\lambda})$. Let S be a finite set of places of F such that $\phi_{v,\lambda} = \phi_{\pi_{v,\lambda}}^0$ and ψ_v is of order zero at any $v \notin S$. Then we have

$$\begin{aligned} M(\tilde{w}, \pi_\lambda)\phi_\lambda &= \Phi_{w(\pi_\lambda)}^{-1} \left(\bigotimes_{v \in S} r(w, \pi_{v,\lambda}, \psi_v) N(\tilde{w}, \pi_{v,\lambda}, \psi_v) \phi_{v,\lambda} \otimes \bigotimes_{v \notin S} r(w, \pi_{v,\lambda}, \psi_v) \phi_{w(\pi_{v,\lambda})}^0 \right) \\ &= r(w, \pi_\lambda) \Phi_{w(\pi_\lambda)}^{-1} \left(\bigotimes_{v \in S} N(\tilde{w}, \pi_{v,\lambda}, \psi_v) \phi_{v,\lambda} \otimes \bigotimes_{v \notin S} \phi_{w(\pi_{v,\lambda})}^0 \right) \\ &= r(w, \pi_\lambda) N(w, \pi_\lambda) \phi_\lambda, \end{aligned}$$

where

$$N(w, \pi_\lambda) \phi_\lambda := \Phi_{w(\pi_\lambda)}^{-1} \left(\bigotimes_{v \in S} N(\tilde{w}, \pi_{v,\lambda}, \psi_v) \phi_{v,\lambda} \otimes \bigotimes_{v \notin S} \phi_{w(\pi_{v,\lambda})}^0 \right).$$

Also, it follows from Prop.5.2 (i) that the finite tensor product $N(w, \pi_\lambda)$ of $N(w, \pi_{v,\lambda}, \psi_v)$ is holomorphic on $C_P(w)$ in Prop.5.2. We conclude the following.

Corollary 5.3. *The poles of $M(w, \pi_\lambda)$ in the region $C_P(w)$ are exactly those of $r(w, \pi_\lambda)$.*

The poles of $r(w, \pi_\lambda)$ can be easily computed. Thanks to Shahidi's non-vanishing theorem [Sha81, Th.5.1], the denominator of $r(w, \pi_\lambda)$ does not vanish on $C_P(w)$, so that the poles in question are exactly those of the numerator of $r(w, \pi_\lambda)$.

Proposition 5.4. *(B₀) Write $\pi = \omega_1 \otimes \omega_2 \otimes \omega$. The poles of $M(w, \pi_\lambda)$, ($w \in W_0$) are*

$$\begin{aligned} \mathfrak{S}_1 &:= (\omega_1 = \omega_2, \lambda_1 = 1 + \lambda_2), & \mathfrak{S}_2 &:= (\omega_2 = \mathbf{1}, \lambda_2 = 1), \\ \mathfrak{S}_3 &:= (\omega_1 = \omega_2^{-1}, \lambda_1 = 1 - \lambda_2), & \mathfrak{S}_4 &:= (\omega_1 = \mathbf{1}, \lambda_1 = 1). \end{aligned}$$

(P₁) Write $\pi = \omega \otimes \tau$. The poles of $M(w_{M_1}, \pi_\lambda)$ are

$$\mathfrak{S}_{E,\theta} := \omega_{E/F} |_{\mathbb{A}} \otimes \pi(\theta) |_{\mathbb{A}} \det |_{\mathbb{A}}^{-1/2},$$

where E/F is a quadratic extension and $\omega_{E/F}$ denotes the quadratic character of $\mathbb{A}^\times / F^\times$ associated to E/F . Also $\pi(\theta)$ is the dihedral type irreducible cuspidal representation of $GL(2, \mathbb{A})$ associated to $\theta \in \Pi(\mathbb{A}_E^\times / E^\times)$ [JL70, Prop.12.1]. (In particular, θ does not factor through the norm $N_{E/F} : \mathbb{A}_E^\times \rightarrow \mathbb{A}^\times$.)

(P₂) We write $\pi = \tau \otimes \omega$. The poles of $M(w_{M_2}, \pi_\lambda)$ are

$$\mathfrak{S}_{\tau,\omega} := \tau |_{\mathbb{A}} \det |_{\mathbb{A}}^{1/2} \otimes \omega |_{\mathbb{A}}^{-1/2},$$

where τ is an irreducible cuspidal representation of $GL(2, \mathbb{A})$ satisfying $\omega_\tau = \mathbb{1}_{\mathbb{A}^\times}$ and $L(1/2, \tau) \neq 0$. Also $\omega \in \Pi(\mathbb{A}^\times / F^\times)$.

Outline of the proof. (B₀) follows from the description of poles of Hecke L -functions, say [Wei95]. (P₂) immediately follows from [JL70, Th.11.1].

(P₁) needs some explanation. First if $\omega(\det)\tau \not\cong \tau$ for any non-trivial $\omega \in \Pi(\mathbb{A}^\times / F^\times)$, $L(s, \text{Ad}^2(\tau) \times \omega)$ is entire by [GJ78, Th.9.3]. Next assume $\omega_{E/F}(\det)\tau \simeq \tau$ for some quadratic

extension E/F . Then [GJ78, (3.7), (9.9)] combined with [LL79, Prop.6.5] imply that $\tau \simeq \pi(\theta)$ for some $\theta \in \Pi(\mathbb{A}_E^\times/E^\times)$. We know from [GJ78, pp. 488–489] that

$$L(s, \text{Ad}^2(\tau) \times \omega) = L_E(s, \theta\sigma(\theta)^{-1}\omega(N_{E/F}))L(s, \omega\omega_{E/F}), \quad (5.1)$$

where σ denotes the generator of the Galois group of E/F . $N_{E/F}$ denotes the norm of E/F . The second factor on the right hand side has its only pole in the region $\Re s \geq 0$ at $(\omega = \omega_{E/F}, s = 1)$ and it is simple. In this case, one can verify that the first factor is entire so that the pole of $L(s, \text{Ad}^2(\tau) \times \omega)$ at $(\omega = \omega_{E/F}, s = 1)$ is simple.

Next let us prove that any pole of $L(s, \text{Ad}^2(\tau) \times \omega)$ in the region $\Re s \geq 0$ can be written in this way (for some other E/F and θ). As in [LL79, §6], we set

$$G(\pi(\theta)) := \{h \in GL(2, \mathbb{A}) \mid \text{Ad}(h)\pi_1 \simeq \pi_1\}, \quad A(\pi(\theta)) := \{\det g \mid g \in G(\pi(\theta))\}.$$

Writing $\pi(\theta) \simeq \otimes_v \pi(\theta_v)$, the set of irreducible components of $\pi(\theta_v)|_{SL(2, F_v)}$ form an L -packet $\Pi_{\pi(\theta_v)}$ at any place v of F . In the above, π_1 is any irreducible cuspidal representation of $SL(2, \mathbb{A})$ in the global L -packet $\otimes_v \Pi_{\pi(\theta_v)}$. If the first factor in the right hand side of (5.1) has a pole, $\theta\sigma(\theta)^{-1}$ is of order two but non-trivial. This implies [LL79, p. 774] that $\mathbb{A}^\times/F^\times A(\pi_\tau) \simeq (\mathbb{Z}/2\mathbb{Z})^{\oplus 2}$. This admits three different quotients isomorphic to $\mathbb{Z}/2\mathbb{Z}$. Correspondingly, we have three distinct data $(E/F, \theta)$, $(E'/F, \theta')$ and $(E''/F, \theta'')$ such that $\pi(\theta) \simeq \pi(\theta') \simeq \pi(\theta'')$. Then, (5.1) becomes

$$L(s, \text{Ad}^2(\tau) \times \omega) = L(s, \omega\omega_{E/F})L(s, \omega\omega_{E'/F})L(s, \omega\omega_{E''/F})$$

and the assertion follows. □

6 Inner product formula

Now we move the integration axis $\Re \lambda = \lambda_0$ in Th.4.3 to the unitary axis $\Re \lambda = 0$.

6.1 The case $P = P_1, P_2$

In this case $\mathfrak{a}_{M, \mathbb{C}}^{G, *}$ is \mathbb{C} , and the difference

$$\int_{\lambda_0 + i\mathfrak{a}_M^{G, *}} A(\phi, \phi')(\pi_\lambda) d\lambda - \int_{i\mathfrak{a}_M^{G, *}} A(\phi, \phi')(\pi_\lambda) d\lambda$$

equals the limit as $T \rightarrow \infty$ of the integral over the path illustrated on the right. By [HC68, Th.101], the intertwining operator $M(w, \pi_\lambda)$ for cuspidal π_λ is bounded on any region of the form $0 \leq \Re \lambda \leq C$. As ϕ, ϕ' are of Paley-Wiener type (in particular, rapidly decreasing in the imaginary part of λ), the contour integrals goes to 0 as T tends to infinity. Thus the usual residue theorem yields the following.

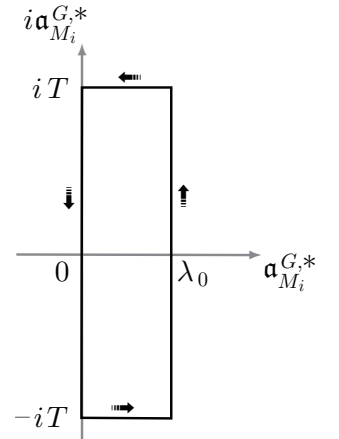

Proposition 6.1. We write $c_F := \text{Res}_{s=1} \zeta_F(s)/\zeta_F(2)$, where $\text{Res}_{s=1}(\cdot)$ denotes the residue at $s = 1$ of (\cdot) and $\zeta_F(s)$ is the complete (i.e., including the archimedean factors) Dedekind zeta function of F .

(i) For $\phi \in P_{(M_1, \pi)}$, $(\pi = \omega \otimes \tau)$, $\phi' \in P_{[M_1, \pi]} := \bigoplus_{(M_1, \pi') \in [M_1, \pi]} P_{(M_1, \pi')}$, we have

$$\langle \theta_\phi, \theta_{\phi'} \rangle = \int_{i\mathbb{R}} A(\phi, \phi')(\pi_\lambda) d\lambda + \frac{c_F L_E(1, \theta\sigma(\theta)^{-1})}{L_E(2, \theta\sigma(\theta)^{-1}) \varepsilon_E(1, \theta\sigma(\theta)^{-1})} \langle N(w_{M_1}, \mathfrak{S}_{E, \theta}) \phi_1, \phi'_1 \rangle.$$

(ii) For $\phi \in P_{(M_2, \pi)}$, $(\pi = \tau \otimes \omega)$, $\phi' \in P_{[M_2, \pi]}$, we have

$$\langle \theta_\phi, \theta_{\phi'} \rangle = \int_{i\mathbb{R}} A(\phi, \phi')(\pi_\lambda) d\lambda + \frac{c_F L(1/2, \tau)}{\sqrt{2} L(3/2, \tau) \varepsilon(1/2, \tau)} \langle N(w_{M_2}, \mathfrak{S}_{\tau, \omega}) \phi_{1/2}, \phi'_{1/2} \rangle.$$

6.2 The case $P = B_0$

In this case, $\mathfrak{a}_{M, \mathbb{C}}^{G, *} = \mathbb{C}^2$ and the singularities of $A(\phi, \phi')(\pi_\lambda)$ are as in the picture on the right. We take a path from λ_0 to 0 as illustrated by the bold line in the picture. We write $y_{\mathfrak{S}_j}$ for the intersection of the path with $\Re \mathfrak{S}_j$. First we have to estimate the contour integrals. The integrand is a sum over $w \in W_0$ of

$$r(w, \pi_\lambda) \langle N(w, \pi_\lambda) \phi_\lambda, \phi'_{-w(\bar{\lambda})} \rangle.$$

The operator $N(w, \pi_\lambda)$ is a composition of the similar operators on $GL(2)$, each of which can be written in terms of a Fourier transform (see [Kon, 3.2]), hence is bounded.

The normalization factor $r(w, \pi_\lambda)$ is a product of factors of the form

$$\frac{L(s, \omega)}{L(s+1, \omega) \varepsilon(s, \omega)}, \quad \omega \in \Pi(\mathbb{A}^\times / F^\times).$$

The exponential function $\varepsilon(s, \omega)$ is bounded on any vertical strip $C_1 \leq \Re s \leq C_2$. It is well-known (see e.g., [Ayo]) that the finite component $L_{\text{fin}}(s, \omega)$ are of the polynomial order in the imaginary part $\Im s$ of s , and $1/L_{\text{fin}}(s+1, \omega)$ is of the polynomial order in $\log(\Im s)$ on a region $-\varepsilon < \Re s$ for some $\varepsilon > 0$. Also Stirling's formula asserts that the quotient $L_\infty(s, \omega)/L_\infty(s+1, \omega)$ of the archimedean components is slowly increasing in $\Im s$ on any vertical strip $0 \leq \Re s \leq C$. These combined with the fact that ϕ_λ is rapidly decreasing in $\Im s$ prove that the contour integral converges to 0 as the contour tends to infinity².

²Thus, in any case, we do not need the ‘‘cut-off integral’’ adopted in [Lan76], [MW94] for the present G . The same is true for any quasisplit group of rank 2.

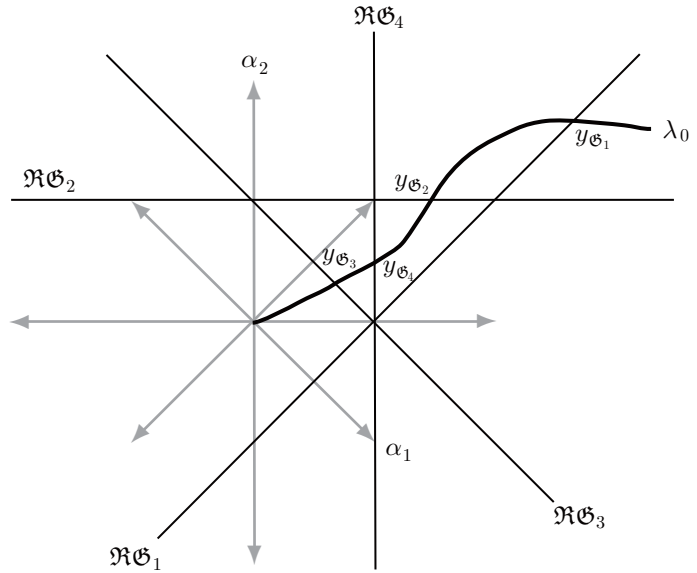

Now the residue theorem yields

$$\begin{aligned} \langle \theta_\phi, \theta_{\phi'} \rangle &= \int_{i\mathfrak{a}_0^{G,*}} A(\phi, \phi')(\pi_\lambda) d\lambda \\ &+ \sum_{j=1}^4 \int_{y_{\mathfrak{S}_j} + i\mathfrak{a}_j^*} \text{Res}_{\mathfrak{S}_j} A(\phi, \phi')(\pi_\lambda) d\lambda, \end{aligned} \quad (6.1)$$

where

$$\begin{aligned} \mathfrak{a}_1^* &:= \{(\lambda, \lambda) \in \mathfrak{a}_0^{G,*}\} = \mathfrak{a}_{M_2}^{G,*}, & \mathfrak{a}_2^* &:= \{(\lambda, 0) \in \mathfrak{a}_0^{G,*}\} = \mathfrak{a}_{M_1}^{G,*}, \\ \mathfrak{a}_3^* &:= \{(\lambda, -\lambda) \in \mathfrak{a}_0^{G,*}\} = r_2(\mathfrak{a}_{M_2}^{G,*}), & \mathfrak{a}_4^* &:= \{(0, \lambda) \in \mathfrak{a}_0^{G,*}\} = r_1(\mathfrak{a}_{M_1}^{G,*}), \end{aligned}$$

and $\text{Res}_{\mathfrak{S}_j} A(\phi, \phi')$ denotes the residue of $A(\phi, \phi')$ along \mathfrak{S}_j . The first row is a $G(\mathbb{A})$ -invariant pairing while the terms in the second row are not.

We now move to the picture on the right. In order to make the latter to be $G(\mathbb{A})$ -invariant, we once more move the integration axis $y_{\mathfrak{S}_j} + i\mathfrak{a}_j^*$ to the “unitary axis” $o(\mathfrak{S}_j) + i\mathfrak{a}_j^*$ of \mathfrak{S}_j . The intersections of two or more singular hyperplanes are possible singularities of $\text{Res}_{\mathfrak{S}_j} A(\phi, \phi')(\pi_\lambda)$. The estimation of the contour integrals still applies to the present situation. It turns out that the stars in the picture are the poles. The circled point is a common pole of several terms in $\text{Res}_{\mathfrak{S}_2} A(\phi, \phi')$, but they cancel

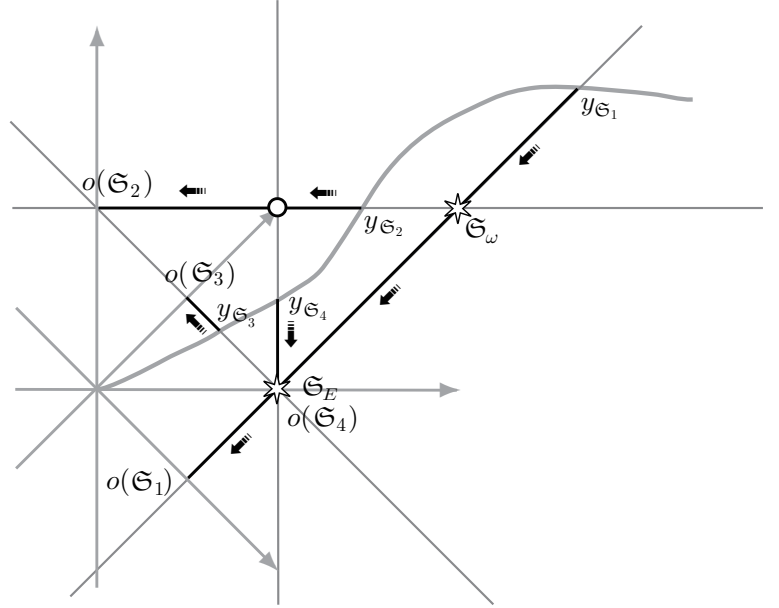

each other, so that the whole thing is holomorphic there.

Proposition 6.2. For $\phi \in P_{(T_0, \pi)}$, ($\pi = \omega_1 \otimes \omega_2 \otimes \omega$), $\phi' \in P_{[T_0, \pi]} := \bigoplus_{(T_0, \pi') \in [T_0, \pi]} P_{(T_0, \pi')}$, we have

$$\begin{aligned} \langle \theta_\phi, \theta_{\phi'} \rangle &= \int_{i\mathfrak{a}_0^{G,*}} A(\phi, \phi')(\pi_\lambda) d\lambda + \sum_{j=1}^3 \int_{o(\mathfrak{S}_j) + i\mathfrak{a}_j^*} \text{Res}_{\mathfrak{S}_j} A(\phi, \phi')(\pi_\lambda) d\lambda \\ &+ \lim_{t \rightarrow 0} \int_{o(\mathfrak{S}_4) + i\mathfrak{a}_4^*} \frac{1}{2} \left(\text{Res}_{\mathfrak{S}_4} A(\phi, \phi')(\pi_{\lambda+t}) + \text{Res}_{\mathfrak{S}_4} A(\phi, \phi')(\pi_{\lambda-t}) \right) d\lambda \\ &+ c_F^2 \langle N(s_2, w_{M_1}(\mathfrak{S}_\omega)) M(s_1 s_2, s_1(\mathfrak{S}_\omega)) N(s_1, \mathfrak{S}_\omega) \phi_{\rho_{B_0}}, \phi'_{\rho_{B_0}} \rangle \\ &+ c_F^2 \langle M(s_2, w_{M_1}(\mathfrak{S}_{E, \omega})) N(s_1, s_2 s_1(\mathfrak{S}_{E, \omega})) M(s_2, s_1(\mathfrak{S}_{E, \omega})) N(s_1, \mathfrak{S}_{E, \omega}) \phi_{(1,0)}, \phi'_{(1,0)} \rangle. \end{aligned}$$

Here, we have written $\mathfrak{S}_\omega := |\cdot|_{\mathbb{A}}^2 \otimes |\cdot|_{\mathbb{A}} \otimes \omega | \cdot |_{\mathbb{A}}^{-3/2}$ and $\mathfrak{S}_{E, \omega} := \omega_{E/F} | \cdot |_{\mathbb{A}} \otimes \omega_{E/F} \otimes \omega | \cdot |_{\mathbb{A}}^{-1/2}$. The second row represents the principal value of $\text{Res}_{\mathfrak{S}_4} A(\phi, \phi')$ at $o(\mathfrak{S}_4)$. Note that $o(\mathfrak{S}_4) \neq \mathfrak{S}_{E, \omega}$, since E runs over the set of (non-trivial) quadratic extensions of F .

7 Spectral decomposition

Now we can deduce the spectral decomposition of the orthogonal complement of $\mathcal{L}_{\text{cusp}}(G)$ in $\mathcal{L}(G)$ from the inner product formulas obtained above.

At any λ whose real part equals $0 \in \mathfrak{a}_M^{G,*}$, or the origin $o(\mathfrak{S})$ of a singular hyperplane \mathfrak{S} , or a 0-dimensional pole \mathfrak{S} , the space of (the residue of) the corresponding Eisenstein series are calculated as follows.

- At $0 \in \mathfrak{a}_M^{G,*}$, the space of cuspidal Eisenstein series $E_P(I_P^G(\pi_\lambda))$, $\lambda \in i\mathfrak{a}_M^{G,*}$.
- At $o(\mathfrak{S}_1) = \omega_1 |_{\mathbb{A}}^{1/2} \otimes \omega_1 |_{\mathbb{A}}^{-1/2} \otimes \omega$ and $o(\mathfrak{S}_3) = \omega_1 |_{\mathbb{A}}^{1/2} \otimes \omega_1^{-1} |_{\mathbb{A}}^{1/2} \otimes \omega \omega_1 |_{\mathbb{A}}^{-1/2} = r_2(o(\mathfrak{S}_1))$, the space of *Siegel Eisenstein series*

$$E_{P_2}(I_{P_2}^G(\omega_1(\det) | \det |^{it} \otimes \omega |^{-it})), \quad (it \in i\mathfrak{a}_{M_2}^{G,*}).$$

- At $o(\mathfrak{S}_2) = \omega_1 \otimes |_{\mathbb{A}} \otimes \omega |_{\mathbb{A}}^{-1/2}$ and $o(\mathfrak{S}_4) = |_{\mathbb{A}} \otimes \omega_1 \otimes \omega |_{\mathbb{A}}^{-1/2} = r_1(o(\mathfrak{S}_2))$, the space of *Klingen Eisenstein series*

$$E_{P_1}(I_{P_1}^G(\omega_1 |^{it} \otimes \omega(\det) | \det |^{-it/2})), \quad (it \in i\mathfrak{a}_{M_1}^{G,*}).$$

- At \mathfrak{S}_ω , the one-dimensional representation $\omega(\nu)$.
- At $\mathfrak{S}_{E,\omega}$, the unique irreducible quotient $J_{P_1}^G(\omega_{E/F} |_{\mathbb{A}} \otimes \pi(\omega(N_{E/F})) | \det |_{\mathbb{A}}^{-1/2})$ of the parabolically induced representation $I_{B_0}^G(\omega_{E/F} |_{\mathbb{A}} \otimes \omega_{E/F} \otimes \omega |_{\mathbb{A}}^{-1/2})$, or of the degenerate principal series representation $I_{P_2}^G(\omega_{E/F}(\det) | \det |_{\mathbb{A}}^{1/2} \otimes \omega |_{\mathbb{A}}^{-1/2})$.
- At $\mathfrak{S}_{E,\theta}$ (see Prop.6.1), the unique irreducible quotient $J_{P_1}^G(\omega_{E/F} |_{\mathbb{A}} \otimes \pi(\theta) | \det |_{\mathbb{A}}^{-1/2})$ of $I_{P_1}^G(\omega_{E/F} |_{\mathbb{A}} \otimes \pi(\theta) | \det |_{\mathbb{A}}^{-1/2})$.
- At $\mathfrak{S}_{\tau,\omega}$, the unique irreducible quotient $J_{P_2}^G(\tau | \det |_{\mathbb{A}}^{1/2} \otimes \omega |_{\mathbb{A}}^{-1/2})$ of $I_{P_2}^G(\tau | \det |_{\mathbb{A}}^{1/2} \otimes \omega |_{\mathbb{A}}^{-1/2})$.

The proof of these result relies on the clasification in the exposition [Kon]. (The archimedean local theory is fully covered by Vogan's Langlands classification [Vog84], [KV95].) Combining these with the result of [Lan76, Ch.7], [MW94, Ch.6], we obtain our final theorem.

Theorem 7.1. *We have a direct sum decomposition $\mathcal{L}(G) = \mathcal{L}_{\text{cusp}}(G) \oplus \mathcal{L}_{\text{res}}(G) \oplus \mathcal{L}_{\text{cont}}(G)$ of unitary representations of $G(\mathbb{A})$ such that:*

(1) $\mathcal{L}_{\text{res}}(G)$ is a Hilbert direct sum of

- One dimensional representation $\omega \circ \nu$, $\omega \in \Pi(\mathbb{A}^\times / F^\times)$;
- The unique irreducible quotient $J_{P_1}^G(\omega_{E/F} |_{\mathbb{A}} \otimes \pi(\omega(N_{E/F})) | \det |_{\mathbb{A}}^{-1/2})$ of the degenerate principal series representation $I_{P_2}^G(\omega_{E/F}(\det) | \det |_{\mathbb{A}}^{1/2} \otimes \omega |_{\mathbb{A}}^{-1/2})$;
- The unique irreducible quotient $J_{P_1}^G(\omega_{E/F} |_{\mathbb{A}} \otimes \pi(\theta) | \det |_{\mathbb{A}}^{-1/2})$ of $I_{P_1}^G(\omega_{E/F} |_{\mathbb{A}} \otimes \pi(\theta) | \det |_{\mathbb{A}}^{-1/2})$;

(d) The unique irreducible quotient $J_{P_2}^G(\tau | \det |_{\mathbb{A}}^{1/2} \otimes \omega |_{\mathbb{A}}^{-1/2})$ of $I_{P_2}^G(\tau | \det |_{\mathbb{A}}^{1/2} \otimes \omega |_{\mathbb{A}}^{-1/2})$.

Here, in (b), (c), E runs over the set of quadratic extensions of F and θ is an element of $\Pi(\mathbb{A}_E^\times / \mathbb{R}_+^\times E^\times)$ which does not pass through the norm $N_{E/F}$. In (d), τ is an irreducible cuspidal representation of $GL(2, \mathbb{A})$ such that $\omega_\tau = \mathbb{1}_{\mathbb{A}^\times}$ (i.e., it is selfdual) and $L(1/2, \tau) \neq 0$. In all cases, ω runs over $\Pi(\mathbb{A}^\times / R_+^\times F^\times)$.

(2) $\mathcal{L}_{\text{cont}}(G)$ is a Hilbert direct sum of continuous sums:

(a) $\int_{i\mathfrak{a}_M^{G,*}} I_P^G(\pi_\lambda) d\lambda$, for $[M, \pi]$ as before.

(b) $\int_{i\mathbb{R}} I_{P_1}^G(\omega_1 |^{it} \otimes \omega(\det) | \det |_{\mathbb{A}}^{-it/2}) dt$, $\omega_1, \omega \in \Pi(\mathbb{A}^\times / F^\times)$.

(c) $\int_{i\mathbb{R}} I_{P_2}^G(\omega_1(\det) | \det |^{it} \otimes \omega |^{-it}) dt$, $\omega_1, \omega \in \Pi(\mathbb{A}^\times / F^\times)$.

A List of the elliptic Arthur parameters for $GS\!p(4)$

An A -parameter for G is a homomorphism $\phi : \mathcal{L}_F \times SL(2, \mathbb{C}) \rightarrow {}^L G$ such that $\phi|_{\mathcal{L}_F}$ is a tempered Langlands parameter for G . Two A -parameters are *equivalent* if they are \widehat{G} -conjugate. Associated to an A -parameter ϕ is the S -group $\mathcal{S}_\phi(G)$, i.e., the group of connected components of the centralizer $S_\phi(G) := \text{Cent}(\phi, \widehat{G})$ of the image of ϕ in \widehat{G} . ϕ is called *elliptic* if $S_\phi(G)^0$ is contained in the center of \widehat{G} .

Conjecturally, for each A -parameter ϕ , we have the associated A -packet $\Pi_\phi(G)$, a (possibly infinite) subset of $\Pi(G(\mathbb{A}))$. $\mathcal{S}_\phi(G)$ controls the endoscopy and hence the contribution to $\mathcal{L}(G)$ of the members of $\Pi_\phi(G)$ through conjectural ‘‘multiplicity pairings’’. We refer the reader [Art89] for the general expectations about these objects. Here we classify the equivalence classes of elliptic A -parameters for $G = GS\!p(4)_F$.

By the natural embedding $\widehat{G} \hookrightarrow GL(4, \mathbb{C})$, we view each A -parameter $\phi : \mathcal{L}_F \times SL(2, \mathbb{C}) \rightarrow \widehat{G} \times W_F$ as a 4-dimensional representation of $\mathcal{L}_F \times SL(2, \mathbb{C})$. Then this admits an irreducible decomposition

$$\phi \simeq \bigoplus_{i=1}^r \varphi_{m_i} \otimes \rho_{d_i},$$

where φ_{m_i} is some m_i -dimensional representation of \mathcal{L}_F and ρ_{d_i} denotes the d_i -dimensional irreducible representation of $SL(2, \mathbb{C})$. We call $\{(m_i, d_i)\}_{1 \leq i \leq r}$ the *Jordan block* of ϕ . We can classify elliptic ϕ using their Jordan blocks as follows.

Jordan block	Labels in Th.7.1	A -parameter	$\mathcal{S}_\phi(G)$	A -packet
$\{(1, 4)\}$	(1.a)	$\omega \otimes \rho_4$	trivial	$\{\omega(\nu)\}$
$\{(2, 2)\}$	(1.c)	$\text{ind}_{W_E}^{W_F}(\theta) \otimes \rho_2$	trivial	$\{J_{P_1}^G((\omega_{E/F} \otimes \pi(\theta))_1)\}$
$\{(2, 1), (1, 2)\}$	(1.d)	$\omega\varphi_\tau \oplus (\omega \otimes \rho_2)$	$\mathbb{Z}/2\mathbb{Z}$	Saito-Kurokawa type
$\{(1, 2), (1, 2)\}$	(1.b)	$\text{ind}_{W_E}^{W_F}(\omega(N_{E/F})) \otimes \rho_2$	$\mathbb{Z}/2\mathbb{Z}$	Howe-PS or θ_{10} -type

Here, $\omega \in \Pi(\mathbb{A}^\times / F^\times)$, $\theta \in \Pi(\mathbb{A}_E^\times / E^\times)$ with $\sigma(\theta) \neq \theta$ and φ_τ is the conjectural Langlands parameter associated to an irreducible cuspidal automorphic representation τ of $GL(2, \mathbb{A})$ satisfying $\omega_\tau = \mathbb{1}_{\mathbb{A}^\times}$. (We do not impose the condition $L(1/2, \tau) \neq 0$.)

References

- [Art89] James Arthur. Unipotent automorphic representations: conjectures. *Astérisque*, (171-172):13–71, 1989. Orbites unipotentes et représentations, II.
- [Ayo] R. Ayoub. *An introduction to the analytic theory of numbers*, volume 10 of *Math. Surveys Monogr.* Amer. Math. Soc.
- [GGJ02] Wee Teck Gan, Nadya Gurevich, and Dihua Jiang. Cubic unipotent Arthur parameters and multiplicities of square integrable automorphic forms. *Invent. Math.*, 149(2):225–265, 2002.
- [GJ78] Stephen Gelbart and Hervé Jacquet. A relation between automorphic representations of $GL(2)$ and $GL(3)$. *Ann. Sci. École Norm. Sup. (4)*, 11(4):471–542, 1978.
- [God63] R. Godement. Domaines fondamentaux des groupes arithmétiques. *Séminaire Bourbaki*, (257), 1962/63.
- [HC68] Harish-Chandra. *Automorphic forms on semisimple Lie groups*, volume 62 of *Lecture Notes in Mathematics*. Springer-Verlag, Berlin, 1968. Notes by J. G. M. Mars.
- [JL70] H. Jacquet and R. P. Langlands. *Automorphic forms on $GL(2)$* , volume 114 of *Lecture Notes in Mathematics*. Springer-Verlag, Berlin, 1970.
- [Kon] Kazuko Konno. Irreducible representations of $GSp(4)$ over a p -adic field. In *this volume*.
- [KV95] Anthony W. Knapp and David A. Vogan, Jr. *Cohomological induction and unitary representations*, volume 45 of *Princeton Mathematical Series*. Princeton University Press, Princeton, NJ, 1995.
- [Lan71] Robert P. Langlands. *Euler products*. Yale University Press, New Haven, Conn., 1971. A James K. Whittemore Lecture in Mathematics given at Yale University, 1967, Yale Mathematical Monographs, 1.
- [Lan76] Robert P. Langlands. *On the functional equations satisfied by Eisenstein series*. Springer-Verlag, Berlin, 1976. Lecture Notes in Mathematics, Vol. 544.
- [LL79] J.-P. Labesse and R. P. Langlands. L -indistinguishability for $SL(2)$. *Canad. J. Math.*, 31(4):726–785, 1979.
- [Mil06] J.S. Milne. *Arithmetic duality theorems*. Booksurge Publishing, 2006. 2nd. edition.
- [MW94] Colette Mœglin and Jean-Loup Waldspurger. *Décomposition spectrale et séries d’Eisenstein*. Birkhäuser Verlag, Basel, 1994. Une paraphrase de l’Écriture.
- [Sha81] Freydoon Shahidi. On certain L -functions. *Amer. J. Math.*, 103(2):297–355, 1981.
- [Sha90] Freydoon Shahidi. A proof of Langlands’ conjecture on Plancherel measures; complementary series for p -adic groups. *Ann. of Math. (2)*, 132(2):273–330, 1990.

- [Tat79] J. Tate. Number theoretic background. In *Automorphic forms, representations and L-functions (Proc. Sympos. Pure Math., Oregon State Univ., Corvallis, Ore., 1977)*, Part 2, pages 3–26. Amer. Math. Soc., Providence, R.I., 1979.
- [Vog84] David A. Vogan, Jr. Unitarizability of certain series of representations. *Ann. of Math.* (2), 120(1):141–187, 1984.
- [Wei95] André Weil. *Basic number theory*. Classics in Mathematics. Springer-Verlag, Berlin, 1995. Reprint of the second (1973) edition.

Index

- $[M, \pi]$, 6
 \mathbb{A}_f , 1
 α^\vee , 7
 α_i ($i = 1, 2$), 6
 α_{M_i} , 7
 Δ_{B_0} , 6
 Δ_{P_i} , 7
K-type, 3
 $\mathbf{K} = \prod_v \mathbf{K}_v$, 2
 \mathbf{K}_∞ , 3
 $\mathcal{A}_{\text{cusp}}(G)$, 3
 $\mathcal{A}_{\text{cusp}}(M)_{\pi_\lambda}$, 5
 $\mathcal{A}_{\text{cusp}}(M)_\pi$, 5
 $\mathcal{A}_{\text{cusp}}(P \backslash G)_{\pi_\lambda}$, 5
 $\mathcal{H}(G(\mathbb{A}))$, 3
 $\mathcal{I}_P^G(\pi_\lambda)$, 5
 $\mathcal{L}(G)$, 2
 $\mathcal{L}(G)_{[M, \pi]}$, 6
 $\mathcal{L}_{\text{cusp}}(G)$, 2
 \mathcal{O}_v , 3
 $\mathfrak{a}_{0, \mathbb{C}}^{G, *}$, 5
 \mathfrak{A}_G , 1
 $\mathfrak{a}_{M_1, \mathbb{C}}^{G, *}$, 5
 $\mathfrak{a}_{M_2, \mathbb{C}}^{G, *}$, 5
 \mathfrak{a}_M^G , 6
 \mathfrak{g}_∞ , 3
 \mathfrak{S}_ω , $\mathfrak{S}_{E, \omega}$, 17
 $\mathfrak{S}_{\tau, \omega}$, 14
 $\mathfrak{S}_{E, \theta}$, 14
 \mathfrak{S}_i , ($1 \leq i \leq 4$), 14
 $\mathfrak{Z}(G(F_\infty))$, 3
 \mathcal{L}_F , 11
 ν , 1
 $\omega_{E/F}$, 14
 ϕ_P , 2
 $\pi(\theta)$, 14
 $\Pi(G(\mathbb{A}))$, 3
 $\psi = \otimes_v \psi_v$, 13
 $\mathfrak{R}\lambda$, 7
 ρ_P , 5
 Σ_{B_0} , 6
 θ_ϕ , 6
 φ_π , 11
 φ_τ , 11
 $\varepsilon(s, \pi \times \omega)$, 4
 $\widehat{\phi}$, 6
 \widehat{G} , 11
 \widehat{U}_i , 11
 \widetilde{w} , 7
 ${}^L B_0$, 11
 ${}^L G$, 11
 ${}^L M_i$, 11
 ${}^L P_i$, 11
 ${}^L T_0$, 11
 $A(\phi, \phi')(\pi_\lambda)$, 8
 $B_0 = T_0 U_0$, 2
 c_F , 16
 $C_P(w)$, 13
 e^λ , 5
 $E_P(\phi_\lambda, g)$, 7
 F_∞ , 1
 F_v , 1
 $I_P^G(\pi_v)$, 12
 $L(s, \text{Ad}^2(\tau) \times \omega)$, 12
 $L(s, \pi \times \omega)$, 4
 $M(\mathbb{A})^1$, 5
 $M(\widetilde{w}, \pi_{v, \lambda})$, 13
 $M(w, \pi_\lambda)$, 7
 $m_{\text{cusp}}(\pi)$, 3
 $N(\widetilde{w}, \pi_{v, \lambda}, \psi_v)$, 13
 $N(w, \pi_\lambda)$, 14
 $P_{(M, \pi)}$, 6
 $P_{[M, \pi]}$, 16
 $P_i = M_i U_i$, 4
 $P_w = w(M) U_w$, 7
 $r(w, \pi_\lambda)$, 11
 $r(w, \pi_{v, \lambda}, \psi_v)$, 13
 r_i , 7
 $w(\pi_\lambda)$, 8
 $W_0 = W_0^G$, 6
 W_{F_v} , 1
 W_F , 1
 w_{M_i} , 7
 $W_M, W(M)$, 7

constant term, 2

cuspidal form, 3

Eisenstein series (cuspidal), 7

Hecke algebra, 3

intertwining operator, 7

Iwasawa decomposition, 3

Paley-Wiener section, 6